



HiPace[®] 350 with TC 110, DN 100 ISO-K



Similar Image

HiPace® 350 with TC 110, DN 100 ISO-K

- Robust, high-performance turbopump with a pumping speed of up to 300 l/s for N₂
- Compact and powerful
- Exceptional pumping speed for light gases
- Laser balancing technology
- For installation in any orientation
- TC 110 integrated electronic drive unit
- Comprehensive accessories extend the range of applications

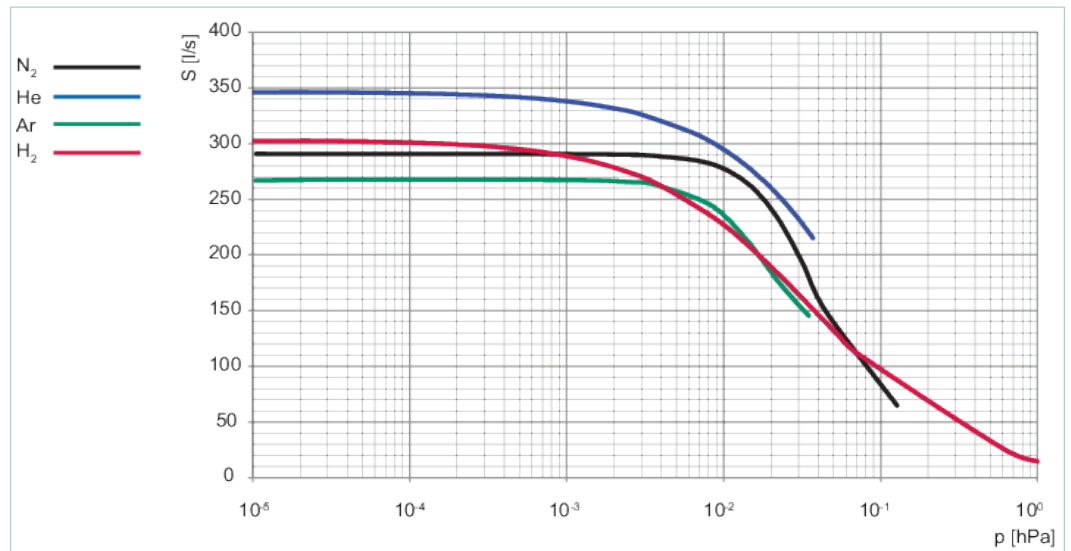

Dimensions

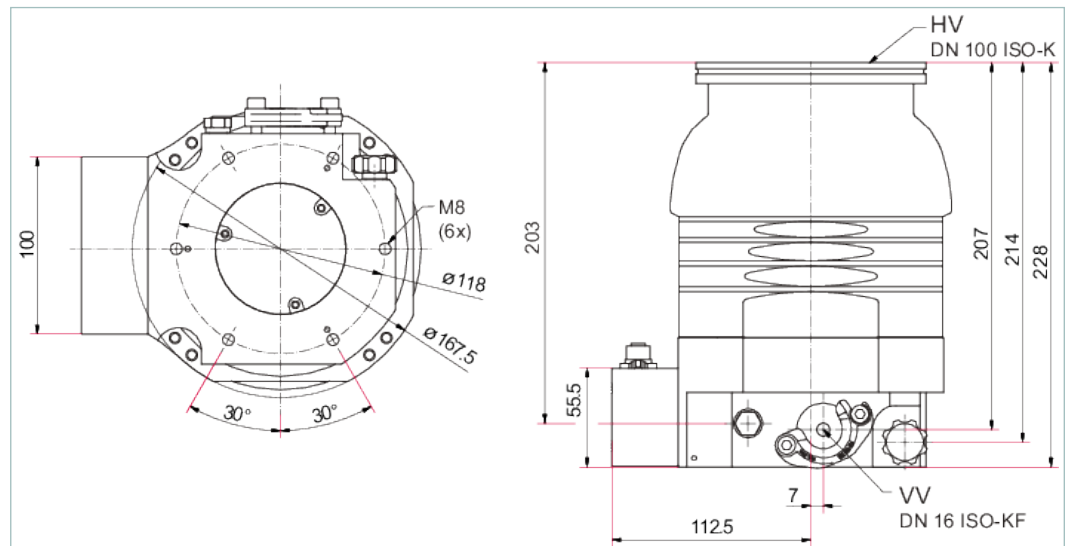

Technical Data

HiPace® 350 with TC 110, DN 100 ISO-K

Bearing	Hybrid
Compression ratio for Ar	$> 1 \cdot 10^{11}$
Compression ratio for H ₂	$2 \cdot 10^6$
Compression ratio for He	$> 1 \cdot 10^8$
Compression ratio for N ₂	$> 1 \cdot 10^{11}$
Connection flange (in)	DN 100 ISO-K

Technical Data	HiPace® 350 with TC 110, DN 100 ISO-K
Connection flange (out)	DN 16 ISO-KF / G 3/8"
Cooling method	Convection
Cooling method, optional	Air Water
Cooling water flow	100 l/h
Cooling water flow, max.	100 l/h
Cooling water flow, min.	100 l/h
Cooling water temperature	15-25 °C 59-77 °F 288-298 K
Current, max.	7.5 A
Electronic drive unit	with TC 110
Final pressure without gas ballast	1 · 10 ⁻⁷ hPa 7.5 · 10 ⁻⁸ Torr 1 · 10 ⁻⁷ mbar
Fore-vacuum max. for N ₂	10 mbar
Gas throughput at final rotation speed for Ar	0.7 mbar l/s
Gas throughput at final rotation speed for H ₂	11 mbar l/s
Gas throughput at final rotation speed for He	7 mbar l/s
Gas throughput at final rotation speed for N ₂	2 mbar l/s
I/O interfaces	RS-485, Remote
Mounting orientation	Arbitrary
Permissible axial magnetic field max.	20 mT
Permissible radial magnetic field max.	4.5 mT
Power consumption max.	180 W
Protection degree	IP54; Type 12
Pumping speed for Ar	270 l/s
Pumping speed for H ₂	300 l/s
Pumping speed for He	350 l/s
Pumping speed for N ₂	300 l/s
Rotation speed ± 2 %	66,000 rpm 66,000 min ⁻¹
Rotation speed variable	60 – 100 %
Run-up time	5.3 min
Sound pressure level	≤50 dB(A)
Venting connection	G 1/8"
Weight	7.2 kg 15.87 lb

Order number	
HiPace® 350	PM P070 401 20

Accessories	
Adapters (electrical) PV-Can	
TIC 010, adapter for two sensors	PT R70 000
Adapters (electrical) Remote	
TCS 17 for control of backing pumps	PM 071 093 -U
D-Sub mains power plug, 15-pin, straight outgoing cable	P 4723 110
D-Sub mains power plug, 15-pin, angled outgoing cable	P 4723 111
Housing for plug, spraywater-protected, 15-pole, D-Sub	P 0998 016
TCS 11, adapter for TC 110/120 with RS-485 interface	PM 061 636 -U
TCS 12, adapter for TC 110/120 with interface RS-485, 4 accessory ports and coupling set	PM 061 638 -U
TCS 13, adapter for TC 110/120 with interface RS-485, 2 accessory ports and coupling set	PM 061 856 -U
Adapters (electrical) RS-232/485	
USB RS-485 converter	PM 061 207 -T
Coupling M12 for RS-485	PM 061 270 -X
Terminal resistor for RS-485	PT 348 105 -T
Power separator for RS-485	PT 348 132 -T
Y-connector M12 for RS-485	P 4723 010
Cables Backing pump control cables	
Control cable for valve	PM 061 687 -T
HiPace – ACP connection cable	PM 071 142 -X
Control cable for pumping stations 0.7 m	PM 061 675 AT
Cables Connection cables	
Connection cable with RS-485 interface and 2 accessory ports for TC110/120 to power supply pack	PM 061 351 -T
Connecting cable from 24V/48V power supply pack to electronic drive unit. With RS-485 interface	PM 061 350 -T
Connection cable for HiPace with TC 110/120	PM 061 543 -T
Connection cable incl. 2 accessory ports for TC 110/120 to power supply pack	PM 061 552 -T
Connection cable with RS-485 interface and 3 accessory ports for TC110/120 to power supply pack	PM 061 512 -T
Cables Extension cables	
Extension cable M8 on M8	PM 061 783 -T
Extension cable M12 on M12	PM 061 747 -T
Cables Mains cables / Power cords	
Mains cable 230 V AC, CEE 7/7 to C13, 3 m	P 4564 309 ZA
Mains cable 115 V AC, NEMA 5-15 to C13, 3 m	P 4564 309 ZE
Mains cable 208 V AC, NEMA 6-15 to C13, 3 m	P 4564 309 ZF
Control Devices Backing pump	
Relay box for backing pumps, 1-phase 20 A for TC 110/120 and TCP 350, plug M8	PM 061 373 -T
Relay box, shielded, for backing pumps, 1-phase 7A for TC 110/120 and TCP 350, plug M8	PM 071 282 -X
Relay box, shielded, for backing pumps, 1-phase 7 A for TC 400/1200, TM 700 and TCP 350, M12	PM 071 284 -X
Relay box, shielded, for backing pumps, 1-phase 20 A for TC 400/1200, TM 700 and TCP 350, M12	PM 071 285 -X

Accessories	
Control Devices Power supplies and control displays	
TPS 180, power supply pack for wall/standard rail installation	PM 061 341 -T
TPS 181, power supply pack 19" plug-in unit 3HU	PM 061 345 -T
Front panel kit for TPS 181	PM 061 394 -T
Accessories package for HPU 001/PC	PM 061 005 -T
OmniControl 001, rack unit without integrated power supply pack	PE D42 100 0
OmniControl 001 Mobile, control units	PE D22 000 0
OmniControl 200, rack unit with integrated power supply pack	PE D52 110 0
OmniControl 200, table unit with integrated power supply pack	PE E52 110 0
Cooling Air cooling	
Air cooling, shielded, for HiPace 350/450 with TC 110/120	PM Z01 373
Shielded air cooling for HiPace 400/700/800 and 300 M/700 M/800 M with TC 400 PB/TM 700	PM Z01 363
Cooling Water cooling	
Water cooling for HiPace 60 P / 80 / 350 / 450 and for SplitFlow 50 / 80 with push-in fitting, 8 mm	PM 016 623 -T
Water cooling for HiPace 350 HiPace 400 HiPace 450 HiPace 700 HiPace 800 with push-in fitting 8 mm	PM 026 068 -T
Monitoring Pressure Sensors	
RPT 010, digital Piezo/Pirani sensor	PT R71 100
IKT 010, digital cold cathode sensor, low current	PT R72 100
IKT 011, digital cold cathode sensor, high current	PT R73 100
Mounting DN ISO-K, Mounting kits, bracket screws	
Mounting kit for HiPace with DN 160 ISO-K, including coated centering ring and bracket screws	PM 016 375 -T
Mounting kit for HiPace 400, DN 100 ISO-K, including coated centering ring, splinter shield, bracket screws	PM 016 381 -T
Mounting kit for HiPace 400, DN 100 ISO-K, including coated centering ring, protection screen, bracket screws	PM 016 382 -T
Mounting kit for HiPace with DN 160 ISO-K, including coated centering ring, protection screen, bracket screws	PM 016 377 -T
Mounting kit for HiPace with DN 160 ISO-K, including coated centering ring, splinter shield and bracket screws	PM 016 376 -T
Mounting DN ISO-K-F, sealings	
Centering ring with multifunction coating, DN 100 ISO-K-F	PM 016 210 -U
Centering ring with multifunction coating, DN 160 ISO-K-F	PM 016 216 -U

Accessories	
Mounting DN ISO-K/F Mounting kits	
Mounting kit for DN 160 ISO-K to ISO-F, with collar flange, coated centering ring, hexagon bolts	PM 016 950 -T
Mounting kit for DN 160 ISO-K to ISO-F, with collar flange, coated centering ring with splinter shield, hexagon bolts	PM 016 951 -T
Mounting kit for DN 160 ISO-K to ISO-F, with collar flange, coated centering ring with protection screen, hexagon bolts	PM 016 952 -T
Mounting kit for DN 160 ISO-K to ISO-F, with collar flange, coated centering ring, stud screws	PM 016 955 -T
Mounting kit for DN 160 ISO-K to ISO-F, with collar flange, coated centering ring with splinter shield, stud screws	PM 016 956 -T
Mounting kit for DN 160 ISO-K to ISO-F, with collar flange, coated centering ring with protection screen, stud screws	PM 016 957 -T
Protection DN ISO-K/F, sealings, splinter shields, protection screens	
Centering ring with multifunction coating and integrated protection screen, DN 100 ISO-K/F	PM 016 212 AU
Centering ring with multifunction coating and integrated splinter shield, DN 100 ISO-K/F	PM 016 807 -U
Centering ring with multifunction coating and integrated splinter shield, DN 160 ISO-K/F	PM 016 217 AU
Centering ring with multifunction coating and integrated protection screen, DN 160 ISO-K/F	PM 016 218 AU
Protection Sealing gas throttles	
Sealing gas throttle for HiPace 300	PM Z01 317
Stainless steel and FKM	
Connection kit for mounting of pumps, DN 16 ISO-KF	120SWS016-1000
Valves Fore-vacuum safety valves	
TVV 001, fore-vacuum safety valve, 230 V AC	PM Z01 205
TVV 001, fore-vacuum safety valve, 115 V AC	PM Z01 206
Valves Sealing gas valves, shielded (normally closed)	
Sealing gas valve, shielded for HiPace 300 with TC 110/120	PM Z01 311
Venting Power failure venting units (normally open)	
Shielded power failure venting unit, 24 V DC, G 1/8", for connection to TC 110/120	PM Z01 330
Venting Venting accessories	
TTV 001, Drier for venting turbopumps	PM Z00 121
Screw-in flange, DN 10 ISO-KF, G 1/8"	PM 033 737 -T
Banjo fitting	PM 016 787 -T
Banjo fitting, small	PM 143 877 -T
Flange with pipe thread, DN 16 ISO-KF, G 1/8"	PM 016 780 -T
Push-in fitting for 6 mm tube, G 1/8"	PM 016 781 -T
Push-in fitting for 8 mm tube, G 1/8"	PM 016 782 -T
Hose nozzle for 9 mm hose, G 1/8"	PM 016 783 -T
Venting Venting valves (normally closed)	
Venting valve, shielded, 24 V DC, G 1/8", for connection to TC 110/120	PM Z01 290
Venting valve, 24 V DC, G 1/8" without cable	PM Z01 293

Accessories	
Vibration Reduction Vibration dampers	
Vibration damper for HiPace 300/400, DN 100 ISO-K/F	PM 006 459 AX
Vibration damper for HiPace with DN 160 ISO-K/F	PM 006 492 AX

VACUUM SOLUTIONS FROM A SINGLE SOURCE

Pfeiffer Vacuum stands for innovative and custom vacuum solutions worldwide, technological perfection, competent advice and reliable service.

COMPLETE RANGE OF PRODUCTS

From a single component to complex systems:

We are the only supplier of vacuum technology that provides a complete product portfolio.

COMPETENCE IN THEORY AND PRACTICE

Benefit from our know-how and our portfolio of training opportunities!

We support you with your plant layout and provide first-class on-site service worldwide.

Are you looking for a
perfect vacuum solution?
Please contact us:

Pfeiffer Vacuum GmbH
Headquarters · Germany
T +49 6441 802-0
info@pfeiffer-vacuum.de

www.pfeiffer-vacuum.com

All data subject to change without prior notice.

PFEIFFER  **VACUUM**